

Localized shear strength mobilization at geosynthetic interfaces caused by spreading soil upslope

Richard Thiel*¹, and Jean-Pierre Giroud²

¹Thiel Engineering, Oregon House, CA, USA

²Consulting Engineer, Paris, France

Abstract. Localized interface shear strength failures have occurred during placement and spreading of cover soils on top of geosynthetic layers on slopes using construction equipment, typically bulldozers ('dozers'). The mechanisms of these types of failures are rarely considered and evaluated in design reports and calculations. The present paper intends to improve upon the analyses presented in previous literature references by providing straightforward equations of static equilibrium that the user can easily input into a spreadsheet to model various dozer sizes, geometries, and shear strengths. The present paper analyzes the shear forces below the soil pile being pushed, as well as below the dozer tracks, which has not been previously considered in the available literature. The equations provided in the present paper should be useful for design engineers to avoid slippage on slopes where dozers are spreading soil materials over geosynthetics, or for forensic experts who evaluate why slippage may have occurred.

1 Introduction

1.1 Construction of thin soil layers above geosynthetic systems

The construction of geosynthetic-lined containment facilities commonly requires a relatively thin layer of soil to be spread over one or more geosynthetic layers. Examples of this include the gravel-drainage layer or the protective-cover-soil layer for a landfill liner, the gravel-drainage layer or the protective-cover-soil layer for a landfill cover, the 'overliner' layer in a heap leach pad, or the protective-cover-soil layer on a pond liner system. The construction sequence by which this occurs is normally to have: (1) the soil delivered to the leading edge of the construction area with haul trucks and dumped in piles; and (2) the piles spread by use of construction equipment, typically a bulldozer (dozer), pushing the soil, preferably in the upslope direction. In the USA, the act of placing and spreading a relatively thin layer of soil over a surface is often called 'veneer' construction, but this term will not be used in the present paper to avoid confusion with translation into other languages.

* Corresponding author: richard@rthiel.com

1.2 Localized shear stress mobilization and detrimental consequences

A key point being addressed in the present paper is that the *localized* shear stresses caused by the soil spreading operation using a dozer are significantly higher than the *average* shear stresses that are assumed to be distributed over the entire slope length.

During the soil-spreading operation, localized shear stresses are mobilized beneath the dozer tracks, and below the pile of soil being spread, due to one or more of the following forces:

- frictional resistance at the base of the soil pile being pushed,
- shear forces due to the weight vector components of the dozer and soil masses that are tangential to the slope, and
- shear forces generated due to acceleration or deceleration of the dozer when performing its tasks.

These shear stresses are transmitted from the base of the dozer tracks and from the base of the soil pile being spread, down to the geosynthetic interfaces of the liner system. If the peak shear strength of any of the interfaces is exceeded by these construction-induced localized shear stresses, then the shear resistance of these interfaces will be degraded as they experience relative displacements during construction. Such localized relative displacements, and the resulting localized shear strength degradation, may or may not be apparent as the construction proceeds. The cumulative effect of localized shear strength degradation events over the course of construction of an entire slope is detrimental to the slope's static and dynamic stability on the long term.

The problem being addressed in the present paper is the preservation of the peak interface shear strength of geosynthetic interfaces below constructed soil layers when there is no explicitly designed tensile reinforcement layer. Excessive displacements during construction could cause other problems, such as geosynthetic stretching, thinning, and bunching, unless the geosynthetic layer has been designed to be anchored and carry a tensile load.

If a design engineer assumes that the peak shear strength of geosynthetic interfaces will still exist after construction on slopes, then it is imperative that the conditions analyzed in the present paper be addressed. In other words, whether the design engineer follows the procedures outlined in the present paper or some other methods, the localized elevated shear stresses induced by the dozer must be evaluated if peak shear strengths are being assumed in the post-construction state for slope stability analyses.

1.3 Slippage occurrence below dozer tracks

An extreme example of localized shear strength degradation would potentially occur if a dozer were used to push too large of a soil pile upslope, causing its tracks to 'spin' in one place. To resolve the issue and proceed with construction, the operator would incrementally take small 'bites' out of the soil pile until it was able to be readily pushed by the dozer. Wherever the dozer tracks were allowed to spin, experienced construction observers would suspect that the underlying geosynthetic interfaces may have been damaged, and require those areas to be exhumed and repaired. More pernicious, however, would be smaller and less obvious slippages than track-spinning occurrences. These could manifest as relative displacements on the order of one to three centimeters, which would be significantly deleterious to the integrity of the interface's shear strength at all locations where that occurred. These types of small, but impactful, slippages could occur over and over without attracting the attention of the dozer operator or the construction observer.

1.4 Literature review

1.4.1 Literature overview

Slope stability analyses that include equipment loading when spreading thin layers of soil on slopes have been published and are often referenced by engineers performing stability calculations. Such references include Richardson and Koerner [1], Koerner and Soong [2], Qian et al. [3], Drushel and Underwood [4], McKelvey [5], and USEPA [6]. These references only consider an entire slope reach, and equipment loads are assumed to be distributed over the entire slope length, often with the objective of calculating the required anchorage strength to secure the geosynthetics, thereby preserving slope stability during this type of construction. To the best knowledge of the authors of the present paper there are only three references that acknowledge the issue of elevated localized shear stresses below the dozer equipment tracks: Paruvakat and Richardson [7], Kerkes [8], and Jones et al. [9]. The authors of the present paper are not aware of any previous publications, including the three just mentioned, that consider the elevated shear stresses below the soil pile that is being spread.

1.4.2 Paruvakat and Richardson [7]

Paruvakat and Richardson [7] considered the localized shear stresses below the dozer tracks for a soil pile being pushed upslope. Their method differs from the one in the present paper in two ways.

The primary difference is the manner in which Paruvakat and Richardson [7] calculated the force required to push the soil pile in front of the dozer. They assumed that the force required to push the soil pile would be a function of the product of the passive lateral earth pressure coefficient and the cosine of the friction angle of the soil against the steel dozer blade. Their model presumes, in essence, that there is a block of soil of infinite length in front of the dozer that is being pushed, and which engages the full classical passive lateral earth pressure of that block against the width of the dozer blade. The primary author of the present paper verified the equations presented by Paruvakat and Richardson [7] and was able to reproduce the results presented in their article. The evaluation performed by the primary author of the present paper concludes that the Paruvakat and Richardson [7] method is unrealistically conservative, when used for design, compared to the model recommended in the present paper to the degree that enforcing its recommendations would greatly penalize the economics of a project by requiring unduly small limits on the amount of soil allowed to be pushed. Incidentally, it should be noted that a method, which is conservative when used for design, is unconservative when used for a forensic analysis, and vice versa.

The second difference between the Paruvakat and Richardson [7] method and the method proposed in the present paper is that the Paruvakat and Richardson [7] method ignores the small passive and active force blocks in the soil layer behind and in front of the dozer tracks, respectively, which are included in a simplistic manner in the present paper. Not only do these lateral force elements represent less than 1% of the driving and resisting forces in the example problem presented herein, but they also tend to cancel each other out. Thus, the decision of whether to ignore or include the active and passive force blocks at the ends of the dozer tracks does not have a significant influence on the results of the analysis.

A substantial contribution of the Paruvakat and Richardson [7] reference is that it is a seminal reference, along with Kerkes [8], recognizing the importance of examining the localized shear stresses during soil spreading on a slope.

1.4.3 Kerkes [8]

Kerkes [8] recognized that existing design methods for equipment loading on slopes do not consider localized shear stresses in the immediate vicinity of the equipment. The Kerkes approach is based on standard equations of static equilibrium where the driving and resisting forces can be estimated based on site-specific assumptions related to the equipment weight, equipment contact area with the ground, equipment acceleration, shear strengths and unit weights of cover soils, shear strengths of geosynthetic interfaces, soil lateral forces, and even geosynthetic tensile forces if desired. The solution algorithm proposed by Kerkes [8] consists in solving for the factor of safety by iteratively changing the assumed values of inter-block normal forces until the results of the calculations converge to a resulting force equilibrium. Because of the complexity introduced by the consideration of the inter-block normal forces between the central block and the passive and active blocks, the equations of equilibrium are complex and require an iterative procedure.

For many years, Kerkes made a spreadsheet available on the internet with a solution for a dozer operating on a slope and spreading soil in an upslope direction. Unfortunately, the internet access to this spreadsheet was removed, and the web page and contact information for Kerkes are also not available. The Kerkes spreadsheet allowed the user to input site-specific values for the slope angle, the weight of the dozer, the dozer track length and width, the soil unit weight and internal shear strength, the assumed angles of inclinations of the active and passive blocks, the thickness of the soil layer, the size of the pile being pushed, and the geosynthetic interface shear strength.

The primary author of the present paper has used the Kerkes spreadsheet to compare its results with the methods proposed in the present paper and found that, for soil internal friction angles less than approximately 30° , similar results are obtained with the Kerkes spreadsheet and the method proposed in the present paper. However, for soil internal friction angles greater than approximately 30° , the Kerkes spreadsheet results in factors of safety that would level off for increasing values of the soil internal friction angle, and the safety factor would then even begin to increase when the soil internal friction angle is approximately $35\text{-}37^\circ$. In contrast, the method proposed in the present paper results in a monotonous trend of decreasing factor of safety with increasing values of the soil internal friction angle. Without detailed investigation into why the Kerkes algorithm gives this result, the authors of the present paper suspect that it is related to the complexity of the solution for the passive block resistance. The primary author of the present paper has verified from actual construction failures that spreading angular gravels that have internal friction angles on the order of 60° is much more likely to result in failure than spreading soils with lower internal friction angles, and therefore does not trust the Kerkes spreadsheet results in this regard. This reversing trend of factors of safety that does not match field experience, and the complexity of the Kerkes equations and solution algorithm, prompted the development of the method proposed in the present paper.

1.4.4 Jones et al. [9]

Jones et al. [9] present finite element numerical modeling results for the shear forces and displacements mobilized at a geosynthetic interface when a dozer is operating over a thin layer of soil on a slope without pushing soil. Their study only modeled the weight of the dozer and the acceleration/deceleration forces for two dozer sizes (Caterpillar models D4 and D6), having deceleration forces ranging from 20 to 40% of the dozer weight, for two slope inclinations (2.5H:1V and 3H:1V), operating on a cover soil layer 0.5 m thick, and having a geomembrane/geotextile peak interface shear strength of 24.5° with an adhesion of 3.2 kPa. Their study did not consider the forces that would be caused by pushing piles of soil. Their

paper concludes that the weight and acceleration forces induced by dozers operating on a thin layer on a slope could result in a shear strength decrease from peak shear strength down to post-peak shear strength being mobilized on textured geomembrane/geotextile interfaces over significant portions of the slope area being covered. No attempt was made in the preparation of the present paper to try to correlate with the results of the Jones et al. [9] paper because the scope of the present paper does not consider acceleration forces, and the Jones et al. [9] paper does not consider push-pile loading. An important value of the Jones et al. [9] paper is that it is one of the few that recognizes the importance of considering the localized shear displacement beneath the operating equipment.

1.5 Direction of pushing

An essential consideration is the direction of pushing on a slope, whether it be upslope, downslope, or cross-slope. It has long been recognized that pushing soil piles over geosynthetic liners in a downslope direction can be dangerous for the liner system (e.g. Koerner and Soong [2]; and Stark et al. [10]). Koerner and Soong [2] provided a quantified analysis that attempted to explain why pushing in a downslope direction can be problematic by attributing the excess driving forces in this case to the acceleration or deceleration of the dozer. Another quantified explanation was provided by Stark et al. [10] who emphasized that the lack of a soil toe buttress when pushing downslope was highly disadvantageous compared to having a toe buttress behind the dozer when pushing upslope. The scope of the present paper is limited to the case of pushing soil piles upslope. The authors of the present paper are preparing a future paper that will address downslope pushing of soil piles, which will provide quantitative proof that pushing downslope is more dangerous for the condition of the geosynthetic interfaces than pushing upslope.

1.6 Limitations of the scope of the present paper

As indicated above, the scope of the present paper is limited to the case of pushing soil piles upslope. Additional limitations are described below.

The analytic approaches described in the present paper do not consider tensile forces in the geosynthetics. If a geosynthetic tensile element is purposely included in the lining system, then the literature papers previously referenced can be used. Alternatively, a tensile element could be added to the model presented in the present paper. Absent an intentionally designed tensile reinforcement layer, it must be assumed that there may exist slack, and/or a relatively low initial tensile stiffness in the upper geosynthetic, such that tensile resistance for a small relative displacement (e.g. 1 to 2 centimeters) is assumed to be negligible. This is the only logical and conservative design assumption if the geosynthetic interface is being counted on for peak shear strength resistance, and if there is no specially designed tensile reinforcement layer to prevent localized relative displacements on the order of 1 to 2 centimeters. If this assumption is not met, then stretching and thinning, or bunching of the geosynthetic may occur, as mentioned in Section 1.2.

The present paper also does not consider the effects of inertial forces due to acceleration or deceleration of the dozer. Inertial forces could be added to the model presented in the present paper. The authors of the present paper are preparing a future paper that will address issues that are not covered in the present paper.

1.7 Organization of the present paper

The present paper is organized as follows:

1. Introduction
2. Definitions and related equations
3. Example analyses of upslope pushing
4. Conclusions

2 Definitions and related equations

2.1 Definition of the considered case

The considered case is that of a dozer pushing a soil pile upslope with the aim of spreading it to a thickness D over the geosynthetic liner system. The slope angle is β . Figure 1 presents the forces acting on a geosynthetic interface below the tracks of the dozer. Figure 2 presents the forces acting on a geosynthetic interface below the base of the soil pile that is being pushed upslope. The forces have been labeled with the nomenclature described in the following sections.

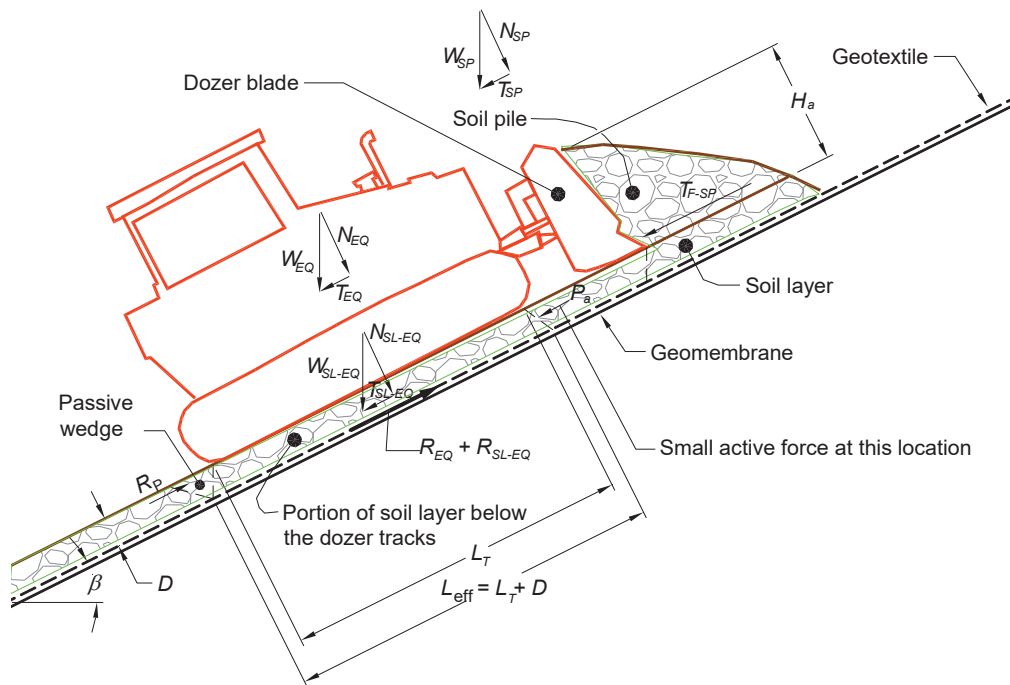

Fig. 1. Forces acting on geosynthetic interface below the tracks of a dozer pushing soil upslope.

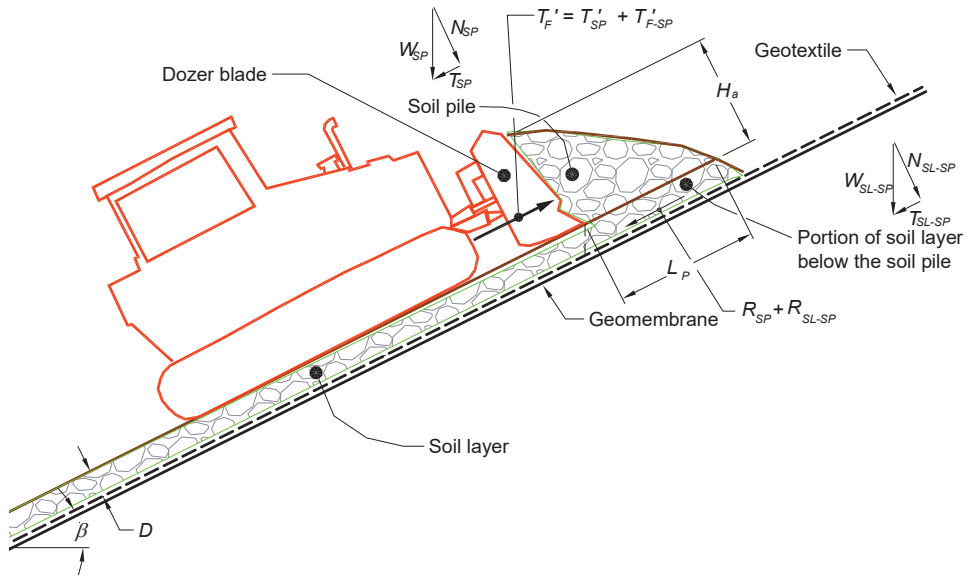

Fig. 2. Forces acting on geosynthetic interface below a soil pile being pushed upslope by a dozer.

2.2 Weights and geometric measurements

W is used to represent the weights as follows:

W_{EQ} is the weight of the dozer (kN).

W_{SP} is the weight of the soil pile being pushed in front of the dozer (kN) where

$$W_{SP} = \gamma V_{SP} \tag{1}$$

where:

γ = unit weight of the soil in being pushed (kN/m³);

V_{SP} = the volume of the soil pile (m³).

W_{SL-EQ} is the weight of the portion of soil layer (kN) below both of the dozer tracks (see Figure 1) acting directly on the area of the geosynthetics that are affected by the weight of the dozer where

$$W_{SL-EQ} = \gamma D A_{eff-EQ} \tag{2}$$

where:

D = the thickness of the soil layer between the dozer tracks and the geosynthetics measured normal to the slope surface (m);

A_{eff-EQ} = the effective area of the geosynthetic interface affected by localized shear stresses induced by both dozer tracks (m²).

Winterkorn and Fang [11] describe how A_{eff} can be estimated by assuming that the total load from the dozer track is distributed over an area of the same shape as the dozer track footprint, but with dimensions that are increased by an amount equal to the thickness D such that

$$A_{eff-EQ} = 2(L_T + D)(w + D) \quad (3)$$

where:

L_T = the length of dozer track in contact with the soil (m) (see Figure 1);

w = width of a single dozer track (m).

W_{SL-SP} is the weight of the portion of soil layer (kN) below the soil pile (see Figure 2) acting directly on the area of the geosynthetics that are affected by the weight of the soil pile where

$$W_{SL-SP} = \gamma D A_{eff-SP} \quad (4)$$

where:

A_{eff-SP} = the effective area of the geosynthetic interface affected by the localized shear stresses induced by the soil pile (m²).

In the same manner as described previously, A_{eff-SP} can be estimated by assuming that the total load from the soil pile is distributed over an area of the same shape as the soil pile footprint, but with dimensions that are increased by an amount equal to the depth D such that

$$A_{eff-SP} = (L_P + D)(B + D) \quad (5)$$

where:

L_P = the length of the soil pile in front of the dozer blade (m) (see Figure 2);

B = the width of the dozer blade, which is assumed to be the same as the width of the soil pile being pushed (m).

For purposes of calculating the pile volume and the dimensions of the pile base, the following simplified relationship for volumetric push capacity, V_S , of a standard straight dozer blade can be used as given by SAE Standard J1265 [12]:

$$V_S = 0.8 B H^2 \quad (6)$$

where:

H = the height of the dozer blade (m).

The volume, V_{SP} , of the soil pile being pushed is assumed to be related to the height of the pile, H_a , being pushed measured normal to the ground surface using the following equation, which is similar to Equation 6:

$$V_{SP} = 0.8 B (H_a)^2 \quad (7)$$

The volume of the soil pile can also be calculated as follows, assuming that the soil pile has a triangular cross section:

$$V_{SP} = 0.5 B L_P H_a \quad (8)$$

where L_P is the length of the soil pile in front of the dozer blade (m).

Combining Equations (7) and (8) results in the following value for the length of the soil pile in front of the dozer blade:

$$L_P = 1.6 H_a \quad (9)$$

The 1.6 ratio between L_P and H_a matches some field observations. However, design engineers are encouraged to adjust the estimate of V_{SP} to suit the conditions appropriate to the project-specific soils, slope, and dozer type in a manner that is representative for the project being designed.

2.3 Force components normal to the slope

N is used to represent the weight vector components that are normal to the slope. Thus, N_{EQ} , N_{SL-EQ} , N_{SP} and N_{SL-SP} are the symbols for the components normal to the slope due to the weights of dozer, portion of soil layer below the tracks, soil pile, and portion of soil layer below the pile, respectively. From the force diagrams shown in Figures 1 and 2, the following generic relationship is applicable to any of these normal forces N :

$$N_{xx} = W_{xx} \cos(\beta) \quad (10)$$

where the subscript xx could represent EQ , $SL-EQ$, SP , or $SL-SP$.

2.4 Force components tangential to the slope and factor of safety

2.4.1 Categories of forces tangential to the slope and factor of safety

There are two categories of forces tangential to the slope: driving and resisting. Driving forces are those that potentially cause slippage at the geosynthetic interface and are collectively labelled S_T . Resisting forces are those that resist slippage at the geosynthetic interface and are collectively labelled R_T . To prevent slippage at the geosynthetic interface during construction would require that

$$R_T > S_T \quad (11)$$

Since this calculation is only for a very short-term condition during construction, there is not a requirement for a factor of safety to be significantly greater than 1.0, provided that the parameters for the calculation are assumed conservatively and the construction is controlled. If a calculated value for the factor of safety, FS , is desired it can be defined as

$$FS = R_T / S_T \quad (12)$$

2.4.2 Driving forces

T is used to represent the driving force vector components that are tangential to the slope. Thus, T_{EQ} , T_{SL-EQ} , T_{SP} , and T_{SL-SP} are the symbols for the tangential driving force components due to the weights of the dozer, portion of soil layer below the tracks, soil pile, and portion

of soil layer below the pile, respectively. From the force diagrams shown in Figures 1 and 2, the following generic relationship is applicable to any of these tangential forces T :

$$T_{xx} = W_{xx} \sin(\beta) \quad (13)$$

where the subscript xx could represent EQ , $SL-EQ$, SP , or $SL-SP$.

Another tangential force vector is the reaction force of the dozer blade, T'_F , against the soil pile as it is pushing the soil pile. This force can be decomposed into two component forces: (1) T'_{SP} , which is the reaction of the dozer blade against the tangential weight component of the soil pile, and (2) T'_{F-SP} , which is the force required to overcome the friction at the base of the soil pile to allow the pile to be spread upslope. When the forces acting on the dozer are of interest (Figure 1), the direction of these two force components is equal and opposite to the force of the dozer blade, and the symbols without a prime, T_{SP} and T_{F-SP} , are used to denote the downslope direction against the dozer. When the forces acting on the soil pile are of interest (Figure 2), the symbols T'_{SP} and T'_{F-SP} are used to denote the upslope direction of the force caused by the dozer blade pushing upslope against the soil pile. Regarding the forces acting on the soil pile, it is also noted that the forces T'_{SP} and T_{SP} cancel each other out and are therefore not carried forward any further in the analyses.

The tangential frictional force T_{F-SP} that is delivered by the dozer blade is manifested at the base of the soil pile as it is being pushed and spread into the desired layer thickness, D . The following classical equation from soil mechanics can then be used:

$$T_{F-SP} = N_{SP} \tan(\phi) \quad (14)$$

where:

ϕ = internal friction angle of the soil being spread (degrees).

A final tangential driving force vector is P_a , which is a small active lateral earth pressure within the soil layer that could act at the upper end of the dozer tracks (see Figure 1). There are complex solutions (which are classical in soil mechanics) for calculating the magnitude of the active lateral earth pressure below an inclined surface and acting on an inclined wall. Methods developed by others for performing stability analyses with active, central, and passive blocks, including Koerner and Soong [2] and Kerkes [8], have proposed solutions that involve complex iterative or quadratic solutions in an attempt to solve for the magnitude and direction of inter-block forces that occur between the central block and either the passive or active blocks. The primary author of the present paper has found those approaches to be more prone to modeling errors, and unlikely to allow the user to clearly discern the relative importance of the different parts of the problem. Clearly the central block is the most important aspect of this problem. Providing simple estimates for the relatively small contributions of the active and passive force blocks, as proposed in the present paper, provides a clear definition of the important elements of the problem.

The relative contribution of the force P_a is small, and is often supposed to be zero thanks to the presence of an assumed 'tension crack' (e.g. Koerner and Soong [2]), or ignored as in the case of Paruvakat and Richardson [7]. Therefore, it is justified to simplify the estimate of the active lateral force at this location by assuming that it is parallel to the slope. Assuming the soil to be cohesionless with an internal friction angle ϕ , and assuming that the width of the active soil block in front of the dozer track is approximately equivalent to the width of the dozer track, w , acting through a vertical soil depth equal to $D/(\cos\beta)$, then the following expression (which is classical in soil mechanics) can be used:

$$P_a = \frac{1}{2} K_a \gamma \left(\frac{D}{\cos \beta} \right)^2 (2w) \quad (15)$$

where the multiplier 2 in front of the term ‘ w ’ accounts for the two dozer tracks, and:

K_a is the active lateral earth pressure coefficient for the soil, which can be estimated as follows using a classical soil mechanics relationship:

$$K_a = \tan^2 \left(45 - \frac{\phi}{2} \right) \quad (16)$$

where ϕ is in degrees.

The sum of the forces potentially causing slippage at the geosynthetic interface below the dozer tracks, collectively called the ‘equipment driving forces’, is S_{T-EQ} , given by the following equation:

$$S_{T-EQ} = T_{EQ} + T_{SL} + T_{SP} + T_{F-SP} + P_a \quad (17)$$

The sum of the forces potentially causing slippage at the geosynthetic interface below the soil pile, collectively called the ‘soil pile driving forces’, is S_{T-SP} , given by the following equation:

$$S_{T-SP} = T_{F-SP} - T_{SL-SP} \quad (18)$$

It should be noted that, because of its downslope direction, the tangential weight component of the soil layer below the soil pile, T_{SL-SP} , is included as a ‘negative driving force’, rather than as a positive resisting force. If the factor of safety, FS , is calculated to be 1.0 according to Equation 12, then this decision is inconsequential. If FS is either more or less than 1.0, then this decision would have an effect on the amount by which the FS is more or less than 1.0.

2.4.3 Resisting forces

R is used to represent the force components tangential to the slope that resist slippage at the geosynthetic interface, either below the dozer or below the soil pile. Thus, R_{EQ} , R_{SL-EQ} , R_{SP} and R_{SL-SP} , are the tangential resisting force components due to the normal forces (defined in Section 2.3) due to the weights of the dozer, portion of soil layer below the tracks, soil pile, and portion of the soil layer below the soil pile, respectively. The following classical relationship applies to these forces:

$$R_{xx} = N_{xx} \tan(\phi) \quad (19)$$

where the subscript xx could represent EQ , $SL-EQ$, SP or $SL-SP$, and δ is the peak critical interface geosynthetic friction angle.

R_p is the passive lateral soil resistance engaged in the soil layer behind the dozer tracks (see Figure 1). A precise computation of this passive lateral force and its vector direction is complex. Using similar arguments as were discussed previously for the active lateral force P_a , a simplified conservative approximation of the passive lateral resistance is proposed using

a reduced passive lateral earth coefficient, K'_p , with the calculated force vector, R_p , acting in the direction tangential to the slope.

A reduced passive lateral earth pressure coefficient, K'_p , for the soil can be estimated as

$$K'_p = 0.3 \tan^2 \left(45 + \frac{\phi}{2} \right) \quad (20)$$

where ϕ is in degrees.

The coefficient 0.3 is included in the formulation of K_p with the intent to limit the passive resistance to small strain conditions that would be compatible with the small deformations (e.g. < 12 mm) that would be allowable at the base of the central block to maintain peak strength conditions.

Based on the above discussion, a conservative estimate of R_p can be calculated as follows:

$$R_p = \frac{1}{2} K_p \gamma D^2 (2w) \quad (21)$$

The multiplier '2' is in front of the term 'w' accounts for the two dozer tracks.

The sum of the total forces resisting slippage at the geosynthetic interface below the dozer tracks, collectively called the 'equipment resisting forces' is R_{T-EQ}

$$R_{T-EQ} = R_p + R_{EQ} + R_{SL-EQ} \quad (22)$$

The sum of the total forces resisting slippage at the geosynthetic interface below the soil pile, collectively called the 'soil pile resisting forces' is R_{T-SP} :

$$R_{T-SP} = R_{SP} + R_{SL-SP} \quad (23)$$

It should be noted that no inertial forces are considered in the above calculations. The act of pushing soil piles upslope is generally not accompanied by acceleration and deceleration of the equipment. This is often not the case when pushing downslope, which is one of the reasons why downslope pushing is much more dangerous for the integrity of the geosynthetics interface than upslope pushing.

3 Example analyses of upslope pushing

3.1 Example problem parameters

A contractor proposes to use a Caterpillar D6D LGP dozer to spread a layer of angular drainage gravel to a thickness, D , of 0.305 m over a geosynthetic liner system on a 3(H):1(V) ($\beta = 18.4^\circ$) slope. The gravel will be delivered to the leading edge of the layer being constructed using tracked dump haul vehicles that traveled very slowly on the slope without changing direction. The dumped piles will then be spread by the dozer. What is the largest volume (V_{SP}) of the gravel pile that should be allowed to be pushed to not exceed the peak shear strength of the critical geosynthetic interface?

The following data are used for this problem:

- The weight of the dozer: $W_{EQ} = 201$ kN
- The track length of the dozer: $L_T = 3.24$ m
- The track width of the dozer: $w = 0.991$ m

- The width of the dozer blade, $B = 3.66$ m
- The unit weight of the gravel: $\gamma = 15.7$ kN/m³
- The internal friction angle of the gravel at the normal loads experienced during construction: $\phi = 60^\circ$ (this is a common value for angular gravels at low normal loads; see, for example, FHWA [13])
- The peak critical interface geosynthetic friction angle between the textured geomembrane and protective geotextile cushion measured in the laboratory at the normal loads experienced during construction: $\delta = 29.2^\circ$

3.2 Calculation no. 1: shear stresses below the dozer tracks

Areas and weights:

$$A_{eff-EQ} = 2(3.24 + 0.305)(0.991 + 0.305) = 9.19 \text{ m}^2 \text{ (Eqn 3)}$$

$$W_{SL-SP} = 15.7(0.305)(9.19) = 44.0 \text{ kN (Eqn 4)}$$

$$W_{SP} = 15.7 \times V_{SP} \text{ kN (Eqn 1)}$$

Normal components:

$$N_{EQ} = 201 \cos(18.4) = 190 \text{ kN (Eqn 10)}$$

$$N_{SL-EQ} = 44.0 \cos(18.4) = 41.8 \text{ kN (Eqn 10)}$$

$$N_{SP} = (15.7 V_{SP}) \cos(18.4) = 14.9 V_{SP} \text{ kN (Eqn 10)}$$

Driving forces:

$$T_{EQ} = 201 \sin(18.4) = 63.4 \text{ kN (Eqn 13)}$$

$$T_{SL-EQ} = 44.0 \sin(18.4) = 13.9 \text{ kN (Eqn 13)}$$

$$T_{SP} = 15.7 V_{SP} \sin(18.4) = 4.96 V_{SP} \text{ kN (Eqn 13)}$$

$$T_{F-SP} = 14.9 V_{SP} \tan(60) = 25.8 V_{SP} \text{ kN (Eqn 14)}$$

Active lateral earth pressure:

$$K_a = \tan^2(45 - 60/2) = 0.072 \text{ (Eqn 16)}$$

$$P_a = (0.5)(15.7) (0.305/\cos(18.4))^2 (0.072)(2)(0.991) = 0.116 \text{ kN (Eqn 15)}$$

Resisting forces:

$$K'_p = (0.3) \tan^2(45 + 60/2) = 4.18 \text{ (Eqn 20)}$$

$$R_p = (0.5)(4.18)(15.7)(0.305)^2 (2)(0.991) = 6.05 \text{ kN (Eqn 21)}$$

$$R_{EQ} = (190) \tan(29.2) = 106 \text{ kN (Eqn 19)}$$

$$R_{SL-EQ} = (41.8) \tan(29.2) = 23.4 \text{ kN (Eqn 19)}$$

To determine the maximum allowable soil pile size that can be pushed without causing slippage below the dozer tracks, set the total resisting forces to be greater than or equal to the total driving forces, and solve for V_{SP} as follows:

$$6.05 + 106 + 23.4 \geq 63.4 + 13.9 + 4.96 V_{SP} + 25.8 V_{SP} + 0.116 \text{ (Eqn 11)}$$

$$\text{Hence } 30.76 V_{SP} \leq 58.03, \text{ hence } V_{SP} \leq 1.89 \text{ m}^3$$

This result indicates that 1.89 m³ is the maximum soil pile volume that can be attempted to be pushed with a factor of safety of 1.0 against slippage below the dozer tracks, and the target could be even less (e.g. 1.5 m³) to allow for a safety factor. It should be noted that the normal 'push load blade' capacity for this common dozer is 3.13 m³.

The maximum height of the soil against the dozer blade being pushed can then be estimated using Equation (7) as follows:

$$H_a \leq [1.89/(0.8 \times 3.66)]^{0.5} = 0.80 \text{ m}$$

The design engineer should check that the dozer blade is higher than 0.80 m.

It is typical for operators to push full loads with their equipment because that maximizes production. Unless told otherwise, that is what will happen, in which case slippages at the base of the tracks will occur, which will degrade the shear strength. Such instances have been noted to occur in the field. The above calculations support a design specification that should limit the size of the gravel pile that is allowed to be pushed upslope.

Calculations performed for this example problem using the method of Paruvakat and Richardson [7] resulted in a maximum allowable height $H_a = 0.38$ m, which, using Equation (7), would result in a maximum allowable pile volume $V_{SP} = 0.42$ m³. This result indicates that using the method of Paruvakat and Richardson [7] would result in an overly conservative design and uneconomical restrictions compared to the method proposed in the present paper.

The above calculations to evaluate the risk of slippage below the dozer tracks are only one aspect of the design example. It is also necessary evaluate the risk of slippage below the soil pile being pushed. This second aspect of the design example is presented in the following section.

3.3 Calculation no. 2: shear stresses below the gravel (soil) pile

For this calculation, the same parameters are used as for Calculation no. 1, but the purpose of this Calculation no. 2 is to determine the maximum gravel pile size to limit shear stresses below the gravel pile that is being pushed.

Areas and weights:

$$A_{eff-SP} = (3.66 + 0.305)[1.6 \times V_{SP}^{0.5} / (0.8 \times 3.66) + 0.305] = 3.71 V_{SP}^{0.5} + 1.21 \text{ m}^2 \quad (\text{Eqn 5, 8 and 9})$$

$$W_{SL-SP} = 15.7(0.305)(3.71 V_{SP}^{0.5} + 1.21) = 17.8 V_{SP}^{0.5} + 5.79 \text{ kN} \quad (\text{Eqn 4})$$

$$W_{SP} = 15.7 V_{SP} \text{ kN} \quad (\text{Eqn 1})$$

Normal components:

$$N_{SL-SP} = (17.8 V_{SP}^{0.5} + 5.79) \cos(18.4) = 16.9 V_{SP}^{0.5} + 5.49 \text{ kN} \quad (\text{Eqn 10})$$

$$N_{SP} = (15.7 V_{SP}) \cos(18.4) = 14.9 V_{SP} \text{ kN} \quad (\text{Eqn 10})$$

Driving forces:

$$T_{SL-SP} = (17.8 V_{SP}^{0.5} + 5.79) \sin(18.4) = 5.62 V_{SP}^{0.5} + 1.83 \text{ kN} \quad (\text{note: the direction of this force is negative as a driving load, as discussed in Section 2.4.2}) \quad (\text{Eqn 13})$$

$$T_{F-SP} = 14.9 V_{SP} \tan(60) = 25.8 V_{SP} \text{ kN} \quad (\text{Eqn 14})$$

Resisting forces:

$$R_{SP} = (14.9 V_{SP}) \tan(29.2) \quad (\text{Eqn 19})$$

$$R_{SL-SP} = (16.9 V_{SP}^{0.5} + 5.49) \tan(29.2) \quad (\text{Eqn 19})$$

$$R_{T-SP} = (14.9 V_{SP} + 16.9 V_{SP}^{0.5} + 5.49) \tan(29.2) = 8.33 V_{SP} + 9.45 V_{SP}^{0.5} + 3.07 \text{ kN} \quad (\text{Eqn 23})$$

To determine the maximum allowable soil pile size that can be pushed without causing slippage, set the total resisting forces greater than or equal to the total driving forces, and solve for V_{SP} as follows:

$$8.33 V_{SP} + 9.45 V_{SP}^{0.5} + 3.07 \geq 25.8 V_{SP} - (5.62 V_{SP}^{0.5} + 1.83) \quad (\text{Eqn 11})$$

$$\text{hence } 17.47 V_{SP} - 4.90 \leq 15.07 V_{SP}^{0.5}$$

$$\text{hence } 305 V_{SP}^2 - 171 V_{SP} + 24 \leq 227 V_{SP}$$

$$\text{hence } 305 V_{SP}^2 - 398 V_{SP} + 24 \leq 0 ;$$

solve the quadratic equation to find:

$$V_{SP} \leq 1.24 \text{ m}^3$$

This result indicates that 1.24 m^3 is the maximum soil pile volume that should be attempted to be pushed is to prevent slippage below the gravel pile, and even less could be considered to provide a safety factor. This is less than the 1.89 m^3 limitation calculated for slippage beneath the dozer. Thus, for this example, it is the potential slippage below the soil pile, and not below the dozer, that is the most critical. This result is not intuitive, but is an artifact of the relatively high internal friction angle of angular gravel. This is illustrated in the following section.

3.4 Graphical comparison of results

The equations described in Section 2 can be set up in a spreadsheet to easily perform a comparison of results and sensitivity analyses. Examples of graphical output from such spreadsheets are presented in Figures 3 and 4 for the design example presented in Section 3. Using such a spreadsheet, that can graphically show the results, avoids the quadratic equation that was used in Calculation no 2, and instead solves for the factor of safety for any assumed soil pile volume, as shown in Figure 4.

Comparing the graphs shown in Figures 3 and 4, it can be observed that the critical location for potential slippage could change from below the soil pile to below the dozer tracks depending on the internal friction angle of the soil being pushed. For two of the soil pile sizes, Figure 5 shows the comparison between the factor of safety for slippage under the soil pile and the factor of safety for slippage below the dozer tracks. For the slope angle, thickness of soil layer being spread, geosynthetic interface friction, and equipment conditions of the design example presented in Sections 3.1 to 3.3, it appears in Figure 5 that an internal friction angle of approximately 56 degrees is the boundary that will determine whether the allowable soil pile size to be pushed will be controlled by slippage below the dozer tracks or below the soil pile. For soils with an internal friction angle lower than 56 degrees under these conditions, the allowable pile size would be governed by slippage below the dozer tracks. For soils with an internal friction angle higher than 56 degrees under these conditions, the allowable pile size would be governed by slippage below the soil pile. The boundary value will be different from 56 degrees for different equipment sizes, layer thickness, and shear strength assumptions. The graphs indicate clearly that constructing with more care and pushing smaller soil piles are required for upslope spreading when the soil being pushed has a higher internal friction angle. It is important to note that, to be representative, the internal friction angle for the soil pile material should be obtained from tests performed under low normal stress.

All curves in both Figures 3 and 4 show that the factor of safety decreases for increasing values of the internal friction angle of the soil being pushed. Therefore, to do a conservative design, the design engineer must overestimate the internal friction angle of the soil being pushed. This is an important recommendation, because design engineers who want to do a conservative design, for example for bearing capacity or slope stability, rightfully underestimate the internal friction angle of the soil. Clearly, for the design of upslope pushing with a dozer, design engineers should not blindly follow their usual tendency. It is important to note that this comment is not applicable to forensic analyses. If a forensic expert investigates why slippage occurred when a dozed pushed, or as a result of upslope pushing with a dozer, the exact internal friction angle should be used or the internal friction angle of the soil should be slightly underestimated for a slightly conservative investigation.

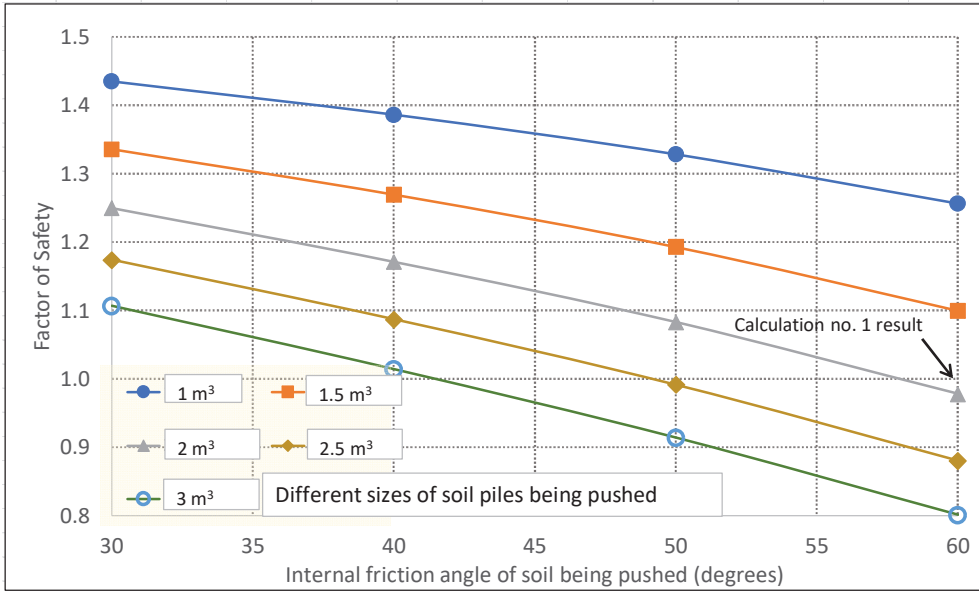

Fig. 3. Soil Friction Angle vs Factor of Safety against slippage 0.305 m below D6D LGP dozer tracks for different soil pile sizes on 3H:1V slope for assumed geosynthetic peak friction angle of 29.2 degrees and other parameters indicated in Section 3.1. Note: For $\phi = 60^\circ$ and a factor of safety of 1.0, the arrow shows the value of 1.89 m³ that corresponds to example calculation no. 1.

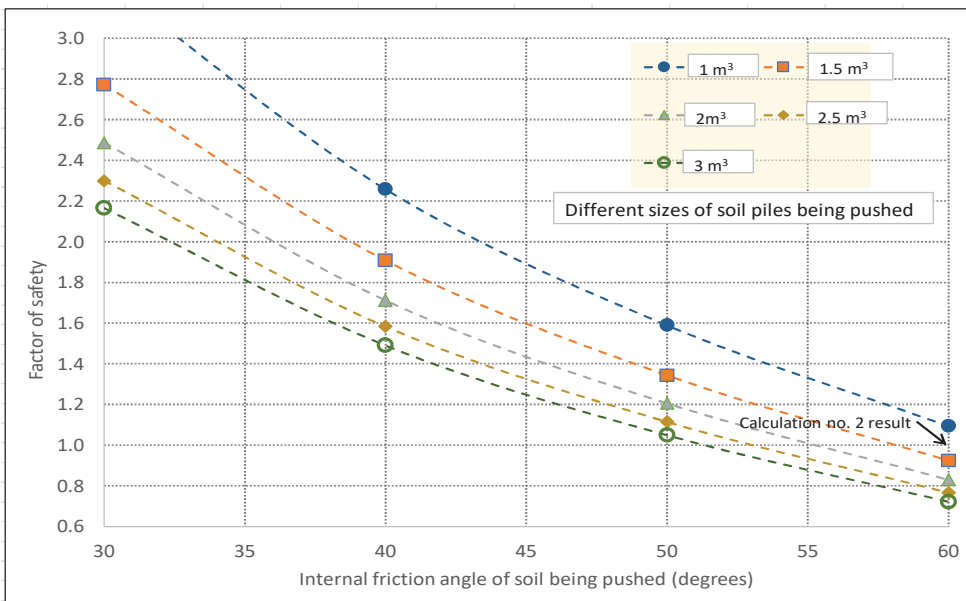

Fig. 4. Soil Friction Angle vs Factor of Safety against slippage 0.305 m below the soil pile for different soil pile sizes on 3H:1V slope for assumed geosynthetic peak friction angle of 29.2 degrees and other parameters indicated in Section 3.1. Note: For $\phi = 60^\circ$ and a factor of safety of 1.0, the arrow shows the value of 1.24 m³ that corresponds to example calculation no. 2.

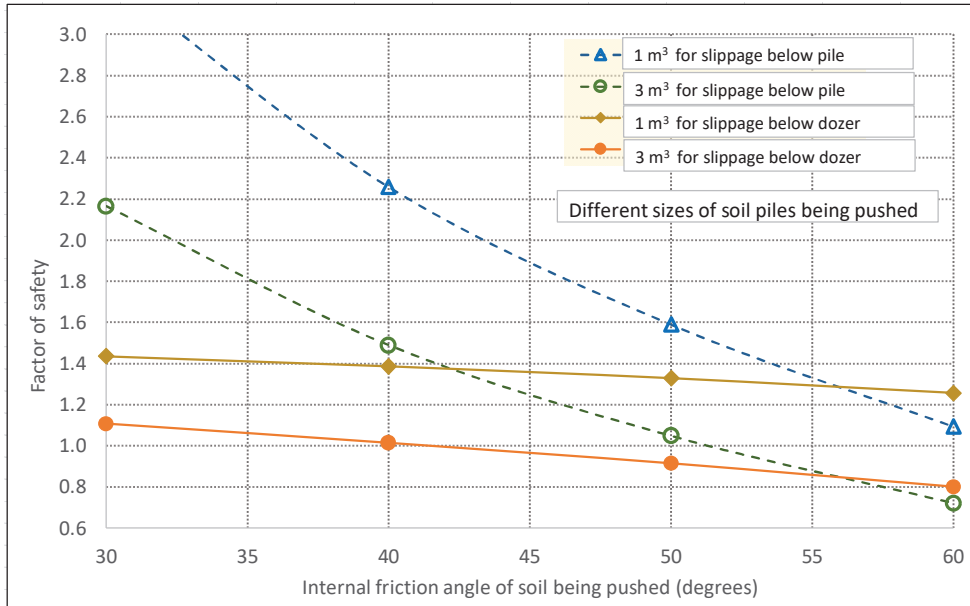

Fig. 5. Comparison of factor of safety for slippage below the soil pile (dashed curves) and slippage below the dozer tracks (solid curves). Note: It can be seen that, for an internal friction angle of the soil being pushed lower than 56° , the factor of safety is controlled by slippage below the dozer tracks. This graph is only applicable to the design example presented in Section 3.

4 Conclusions

Localized interface shear strength failures have occurred during placement and spreading of cover soils on top of geosynthetic layers on slopes. If a design engineer evaluating slope stability assumes that the peak shear strength of geosynthetic interfaces will exist after spreading soil layers above geosynthetics on slopes, then project specific calculations should be performed to determine the size of dozer and maximum size of soil piles that can be pushed without causing damage. Factors that affect these calculations include the slope angle, the internal shear strength of the soils being spread, the interface shear strength of the critical geosynthetic interface, the thickness of the soil layer being spread over the geosynthetics, and the characteristics of the dozer such as its weight and the contact area of its tracks.

Previous literature references on this subject were evaluated and found to be either overly conservative to the point of affecting project construction economics, or numerically complex and prone to errors. Furthermore, some of these references provide only a few examples based on numerical simulations for limited conditions that could not be extrapolated to situations other than those modelled. The present paper is based on easily understood principles of statics and contains simplifying assumptions for lateral soil forces that have relatively little impact on the results and that often result in complex solutions. The equations provided in the present paper are easy to program on a spreadsheet for any project-specific situation, and can be extended to incorporate other factors not included in the present paper such as tensile reinforcement and inertial forces.

The results of the examples evaluated in the present paper indicate that constructing with more care and pushing smaller soil piles are required for upslope spreading as higher values of the internal friction angle of the soil are considered. Great care should be exercised when spreading cohesionless materials that have a high friction angle.

The authors would like to acknowledge the assistance of Zehong Yuan who provided valuable information related to the shear strength of crushed angular gravels on soil cover applications.

References

1. G. Richardson and R.M. Koerner, *Geosynthetic Design Guidance for Hazardous Waste Landfill Cells and Surface Impoundments.*, EPA-600/2-87-097. USEPA, (1987)
2. R.M. Koerner and T.Y. Soong, *Analysis and Design of Veneer Cover Soils*, Proc. of 6th Int'l Conf. on Geosynthetics, 25-29 March 1998, Atlanta, GA, IFAI, (1998)
3. X. Xian, R.M. Koerner, and D. Gray, *Geotechnical Aspects of Landfill Design and Construction*, Pearson (publ), 1st Ed. (2001)
4. S.J. Drushel and E.R. Underwood, *Design of Lining and Cover System Side Slopes*, Proc. of Geosynthetics '93, March 30-April 1, 1993, Vancouver B.C. IFAI, pp. 1341-1355 (1993)
5. J.A. McKelvey, *Consideration of Equipment Loadings in Geosynthetic Lined Slope Designs*, Computer Methods and Advances in Geomechanics, Siriwardane and Zaman (Eds.) Balkema, Rotterdam, pp. 1371-1377 (1994)
6. USEPA, *EPA (Draft) Technical Guidance For RCRA/CERCLA Final Covers*, Office of Solid Waste and Emergency Response, EPA 540-R-04-007, OSWER 9283.1-26, (2004)
7. N. Paruvakat and G. Richardson, *Landfill Cover Failure Prompts Standards Upgrade*, GFR Magazine, **17** N7, IFAI (1999)
8. D.J. Kerkes, *Analysis of Equipment Loads on Geocomposite Liner Systems*, Proc. of Geosynthetics '99 held April 28-30, 1999 in Boston, MA. IFAI, pp. 1043-1054. Example spreadsheet formerly downloaded from <http://www.geotechconsultant.com/articles.htm> but no longer available (1999)
9. D.R.V. Jones, N. Dixon, and A. Connell, *Effect of Landfill Construction Activities on Mobilized Interface Shear Strength*, Proc. EuroGeo 2000, Bologna, Italy, pp. 581-586 (2000)
10. T.D. Stark, H. Choi, C. Lee, and B. Queen, *Compacted Soil Liner Interface Strength Importance*, ASCE JGGE, **138** N4, pp. 544-550 (2012)
11. H.F. Winterkorn and H.Y. Fang, *Foundation Engineering Handbook*, Van Nostrand Reinhold, New York (1975)
12. SAE, Standard J1265, Capacity Rating – Dozer Blades. (Cancelled 2003 and superseded by SAE JISO 9246, Earth-moving machinery Crawler and wheel tractor dozer blades Volumetric ratings) (2003)
13. FHWA, *Friction Angles of Open-Graded Aggregates from Large Scale Direct Shear Testing*, Techbrief FHWA-HRT-13-068, Federal Highway Administration, www.fhwa.dot.gov/research (2013)